

Machine Guarding



Introduction

Crushed hands and arms, severed fingers, blindness - the list of possible machinery-related injuries is as long as it is horrifying. Safeguards are essential for protecting workers from needless and preventable injuries.

A good rule to remember is: Any machine part, function, or process which may cause injury must be safeguarded.

Where the operation of a machine can injure the operator or other workers, the hazard must be controlled or eliminated.

Causes of Machine Accidents

- ❑ Reaching in to “clear” equipment
- ❑ Not using Lockout/Tagout
- ❑ Unauthorized persons doing maintenance or using the machines
- ❑ Missing or loose machine guards

Where Mechanical Hazards Occur

- Point of operation
- All parts of the machine which move, such as:
 - flywheels, pulleys, belts, couplings, chains, cranks, gears, etc.
 - feed mechanisms and auxiliary parts of the machine
- In-running nip points

Point of Operation

That point where work is performed on the material, such as cutting, shaping, boring, or forming of stock must be guarded.



Rotating Parts

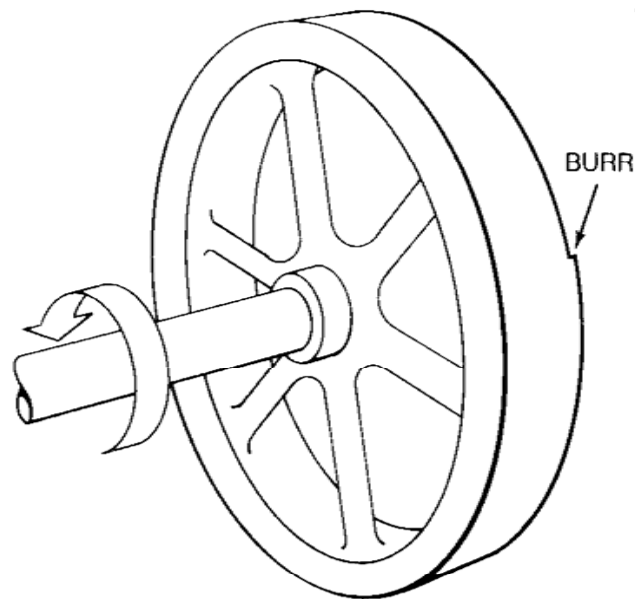

ROTATING PULLEY WITH SPOKES AND PROJECTING BURR ON FACE OF PULLEY

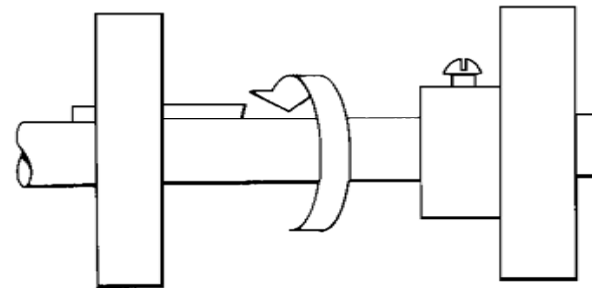

ROTATING SHAFT AND PULLEYS WITH PROJECTING KEY AND SET SCREW

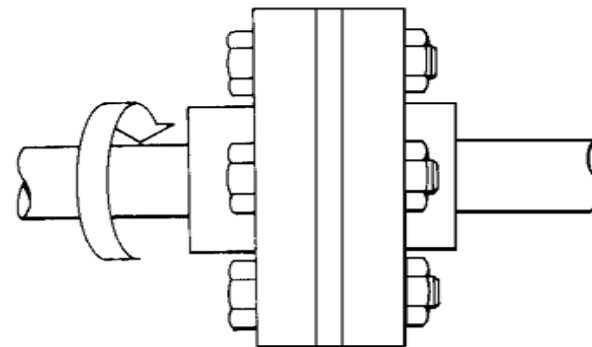

ROTATING COUPLING WITH PROJECTING BOLT HEADS

In-Running Nip Points

Rotating cylinders

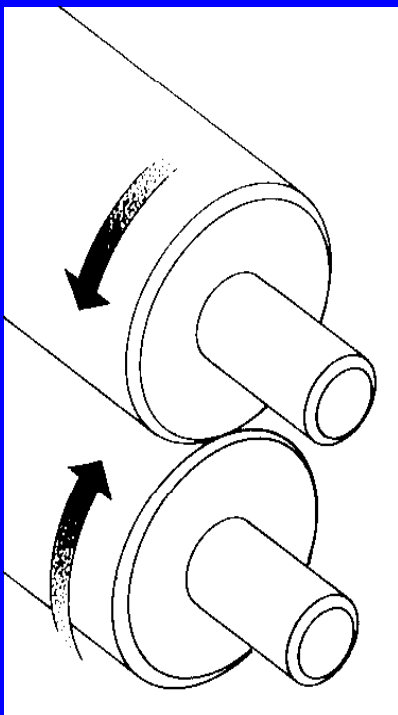

Belt and pulley

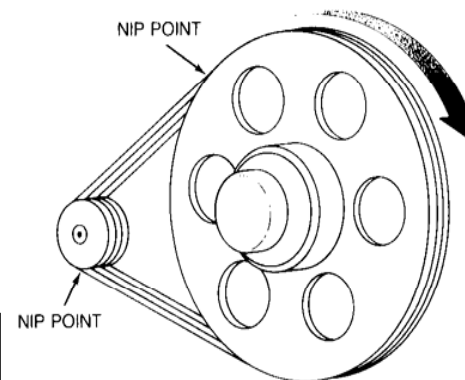

Chain and sprocket

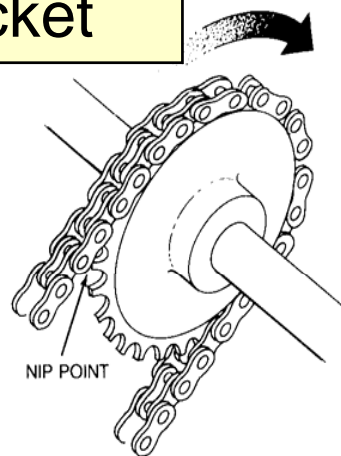

Rack and pinion

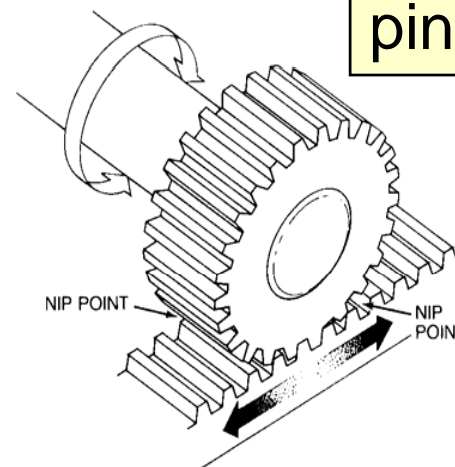

Requirements for Safeguards

- ❑ Prevent contact - prevent worker's body or clothing from contacting hazardous moving parts
- ❑ Secure - firmly secured to machine and not easily removed
- ❑ Protect from falling objects - ensure that no objects can fall into moving parts
- ❑ Create no new hazards - must not have shear points, jagged edges or unfinished surfaces
- ❑ Create no interference - must not prevent worker from performing the job quickly and comfortably
- ❑ Allow safe lubrication - if possible, be able to lubricate the machine without removing the safeguards

Methods of Machine Safeguarding

- Guards
 - fixed
 - interlocked
 - adjustable
 - self-adjusting
- Devices
 - presence sensing
 - pullback
 - restraint
 - safety controls (tripwire cable, two-hand control, etc.)
 - gates
- Location/distance
- Feeding and ejection methods
 - automatic and/or semi-automatic feed and ejection
 - robots
- Miscellaneous aids
 - awareness barriers
 - protective shields
 - hand-feeding tools

Fixed Guard

Provides a barrier - a permanent part of the machine, preferable to all other types of guards.

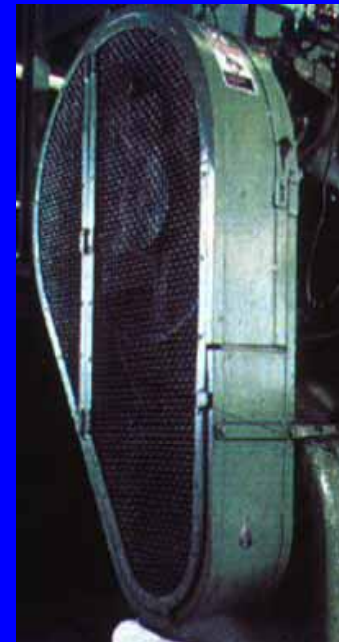

Interlocked Guard

When this type of guard is opened or removed, the tripping mechanism and/or power automatically shuts off or disengages, and the machine cannot cycle or be started until the guard is back in place.



Interlocked
guard on
revolving drum

Adjustable Guard

Provides a barrier which may be adjusted to facilitate a variety of production operations.



Bandsaw blade
adjustable guard

Self-Adjusting Guard

Provides a barrier which moves according to the size of the stock entering the danger area.



Circular table saw
self-adjusting guard

Pullback Device

- ❑ Utilizes a series of cables attached to the operator's hands, wrists, and/or arms
- ❑ Primarily used on machines with stroking action
- ❑ Allows access to the point of operation when the slide/ram is up
- ❑ Withdraws hands when the slide/ram begins to descend



Pullback Device (cont'd)



- Hands in die, feeding
- Point of operation exposed
- Pullback device attached and properly adjusted



- Die closed
- Hands withdrawn from point of operation by pullback device

Restraint Device

- ❑ Uses cables or straps attached to the operator's hands and a fixed point
- ❑ Must be adjusted to let the operator's hands travel within a predetermined safe area
- ❑ Hand-feeding tools are often necessary if the operation involves placing material into the danger area



Safety Tripwire Cables

- Device located around the perimeter of or near the danger area
- Operator must be able to reach the cable to stop the machine



Two-Hand Control

- Requires constant, concurrent pressure to activate the machine
- The operator's hands are required to be at a safe location (on control buttons) and at a safe distance from the danger area while the machine completes its closing cycle

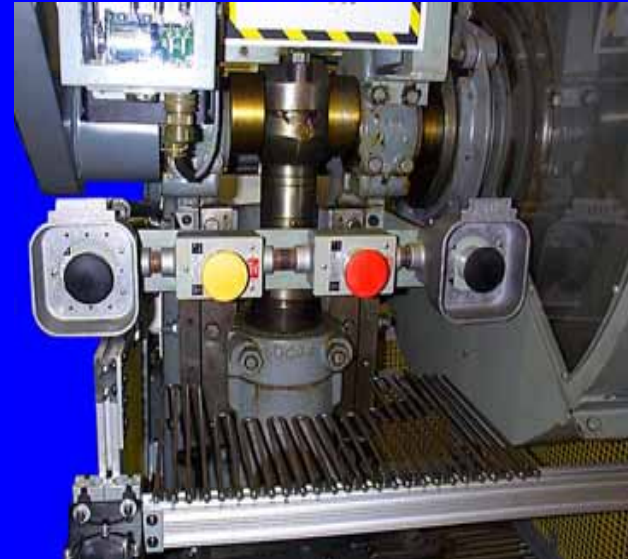

Gate

- Movable barrier device which protects the operator at the point of operation before the machine cycle can be started
- If the gate does not fully close, machine will not function



Gate Open



Gate Closed

Safeguarding by Location/Distance

- Locate the machine or its dangerous moving parts so that they are not accessible or do not present a hazard to a worker during normal operation
- Maintain a safe distance from the danger area



Automatic Feed (shown on power press)

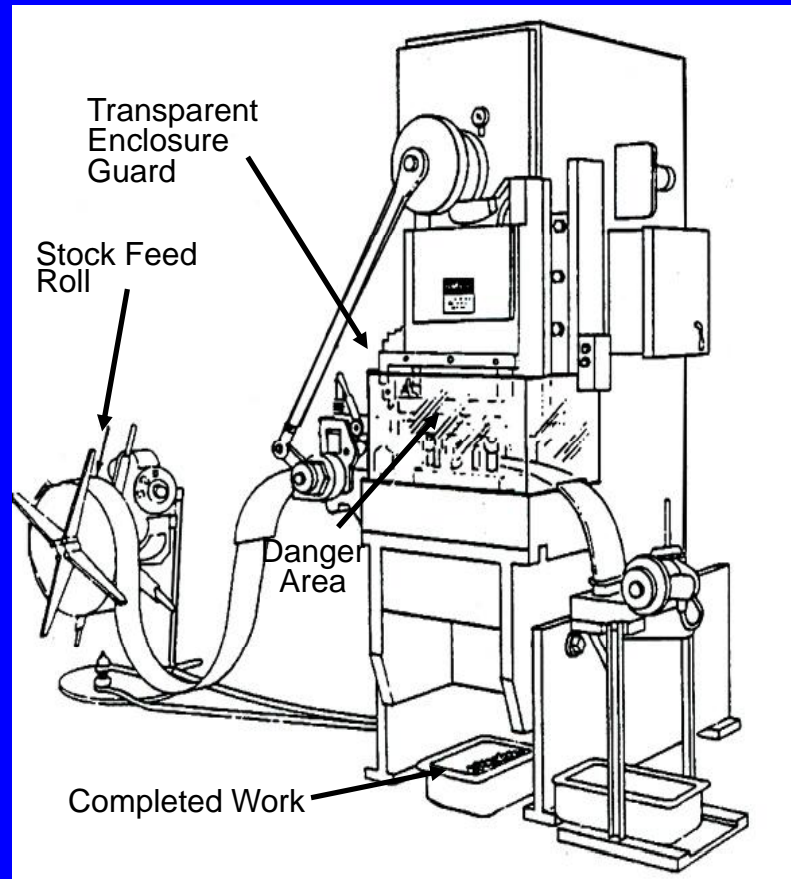

Robots

- Machines that load and unload stock, assemble parts, transfer objects, or perform other tasks
- Best used in high-production processes requiring repeated routines where they prevent other hazards to employees

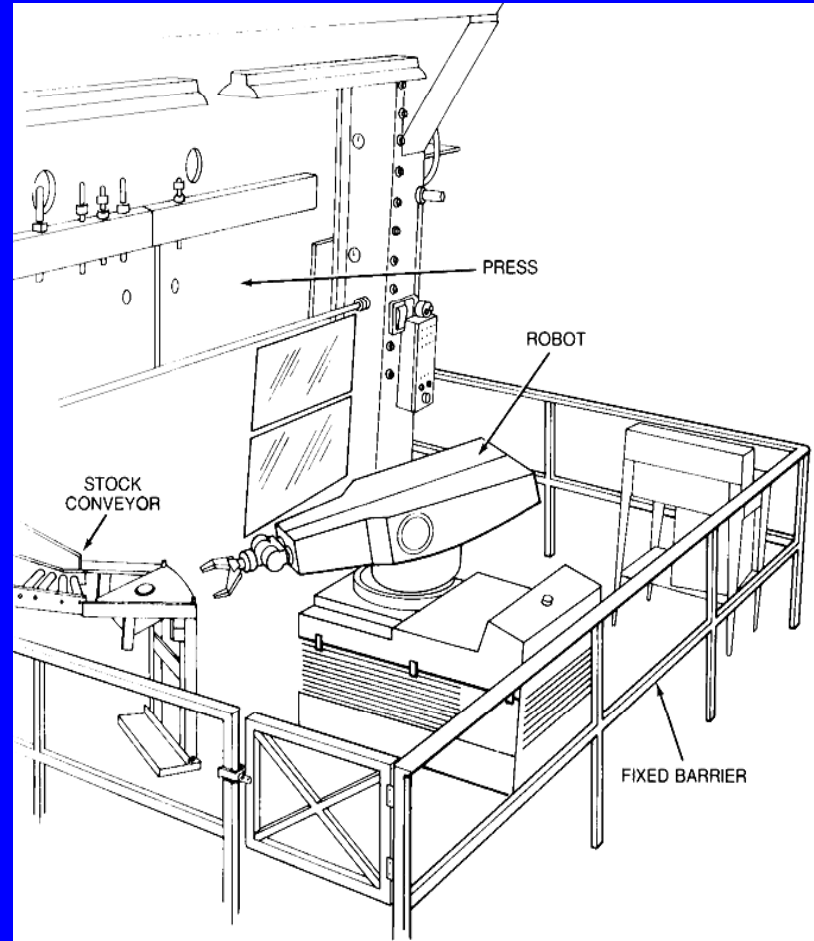

Protective Shields

These do not give complete protection from machine hazards, but do provide some protection from flying particles, splashing cutting oils, or coolants.

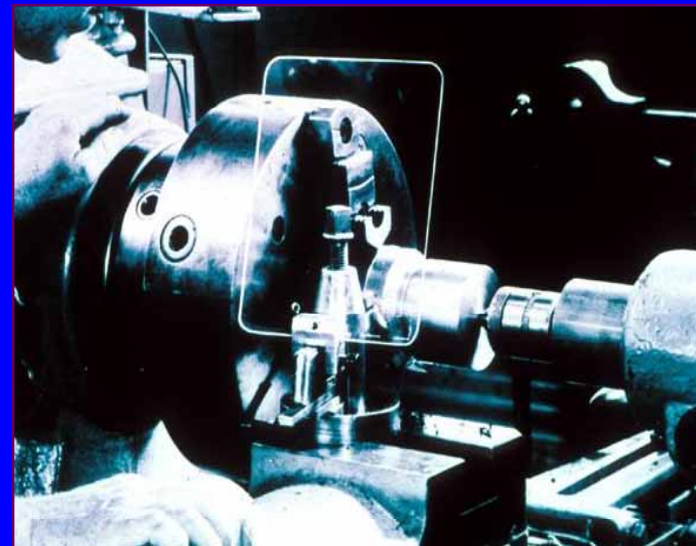

Holding Tools

- ❑ Used to place and remove stock in the danger area
- ❑ Not to be used instead of other machine safeguards, but as a supplement

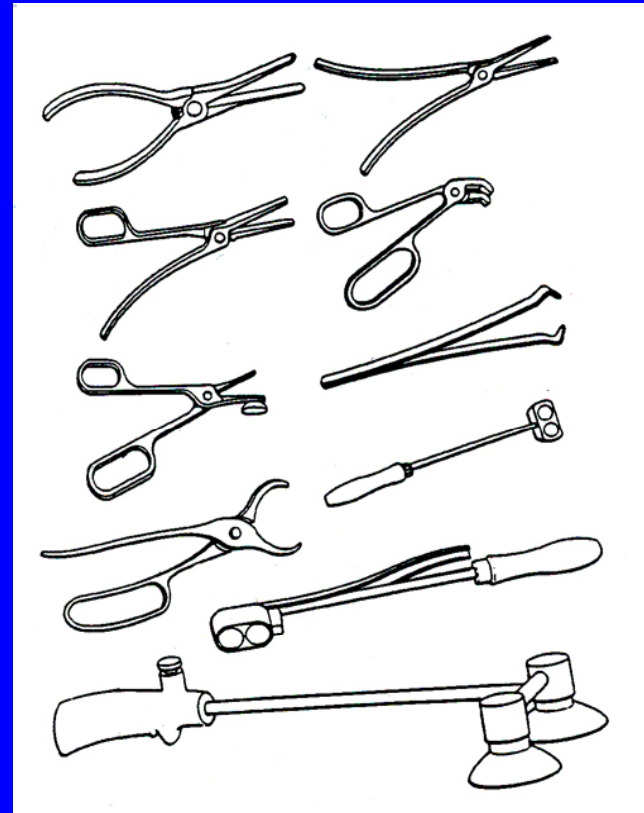

Some Examples of OSHA Machine Guarding Requirements

Guarding Fan Blades

When the periphery of the blades of a fan is less than 7 feet above the floor or working level, the blades must be guarded with a guard having openings no larger than 1/2 inch.

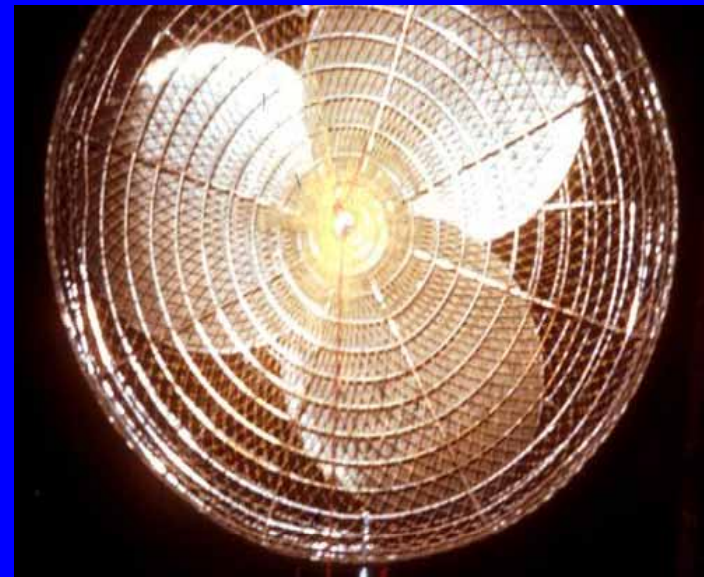

Abrasive Wheel Machinery

Work rests on offhand grinding machines must be kept adjusted closely to the wheel with a maximum opening of 1/8-inch to prevent the work from being jammed between the wheel and the rest, which may result in wheel breakage.

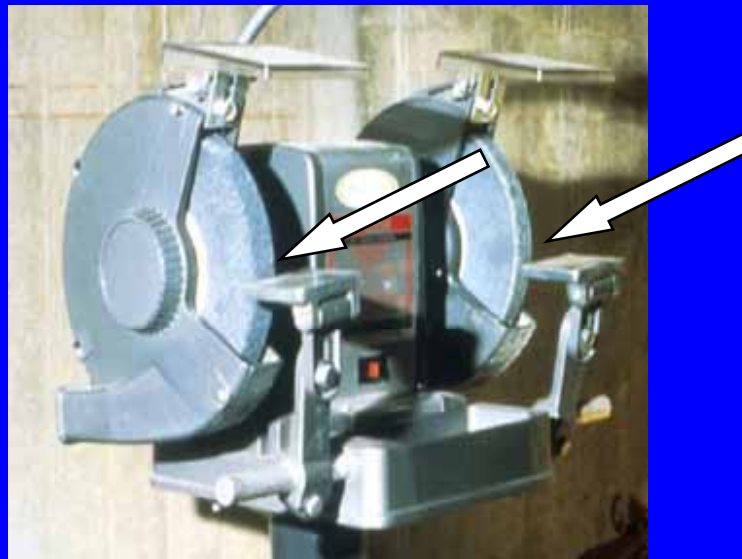

Abrasive Wheel Machinery

The distance between the wheel periphery and the adjustable tongue must never exceed 1/4-inch.

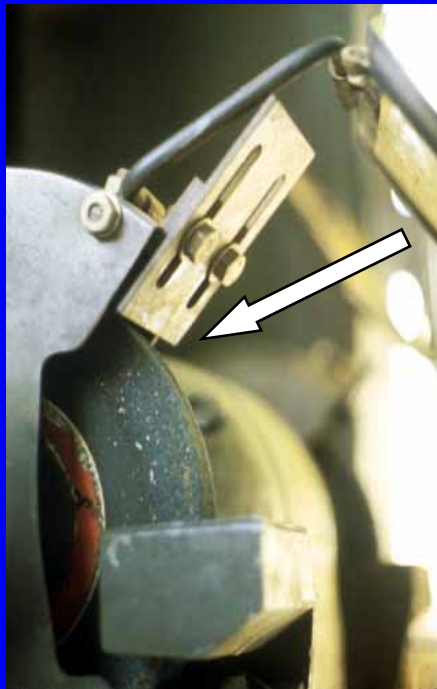

Power-Transmission Apparatus

Power-transmission apparatus (shafting, flywheels, pulleys, belts, chain drives, etc.) less than 7 feet from the floor or working platform must be guarded.

Unguarded belt and pulley



Machine Safety Responsibilities

- Management
 - ensure all machinery is properly guarded
- Supervisors
 - train employees on specific guard rules in their areas
 - ensure machine guards remain in place and are functional
 - immediately correct machine guard deficiencies
- Employees
 - do not remove guards unless machine is locked and tagged
 - report machine guard problems to supervisors immediately
 - do not operate equipment unless guards are in place

Training

Operators should receive training on the following:

- Hazards associated with particular machines
- How the safeguards provide protection and the hazards for which they are intended
- How and why to use the safeguards
- How and when safeguards can be removed and by whom
- What to do if a safeguard is damaged, missing, or unable to provide adequate protection

Summary

- Safeguards are essential for protecting workers from needless and preventable machinery-related injuries
- The point of operation, as well as all parts of the machine that move while the machine is working, must be safeguarded
- A good rule to remember is: *Any machine part, function, or process which may cause injury must be safeguarded*